



(19) **United States**

(12) **Patent Application Publication** (10) **Pub. No.: US 2005/0017630 A1**

Ryu et al.

(43) **Pub. Date: Jan. 27, 2005**

(54) **FLAT PANEL DISPLAY WITH HIGH EFFICIENCY AND METHOD OF FABRICATING THE SAME**

Publication Classification

(51) **Int. Cl.⁷ H05B 33/00; H05B 33/10**

(52) **U.S. Cl. 313/504; 313/503; 313/506; 445/24; 427/66**

(76) **Inventors: Seung-Yoon Ryu, Seoul (KR); Seung-Yong Song, Yongin-si (KR)**

(57) **ABSTRACT**

An organic light emitting device is disclosed. In one embodiment, the organic light emitting device includes red (R), green (G) and blue (B) lower electrodes formed on a substrate. R, G, B organic thin film layers are formed on the R, G, B lower electrodes, respectively. Additionally, an upper single or multilayer electrode is formed over the substrate. Portions of the upper electrode that correspond to the R, G, B organic thin film layers, respectively, are formed to each have a different thickness. Various methods for forming the upper electrode using a fine metal mask, a halftone mask, and single and multiple photolithography processes are also disclosed.

Correspondence Address:
MCGUIREWOODS, LLP
1750 TYSONS BLVD
SUITE 1800
MCLEAN, VA 22102 (US)

(21) **Appl. No.: 10/896,011**

(22) **Filed: Jul. 22, 2004**

(30) **Foreign Application Priority Data**

Jul. 26, 2003 (KR) 2003-51811

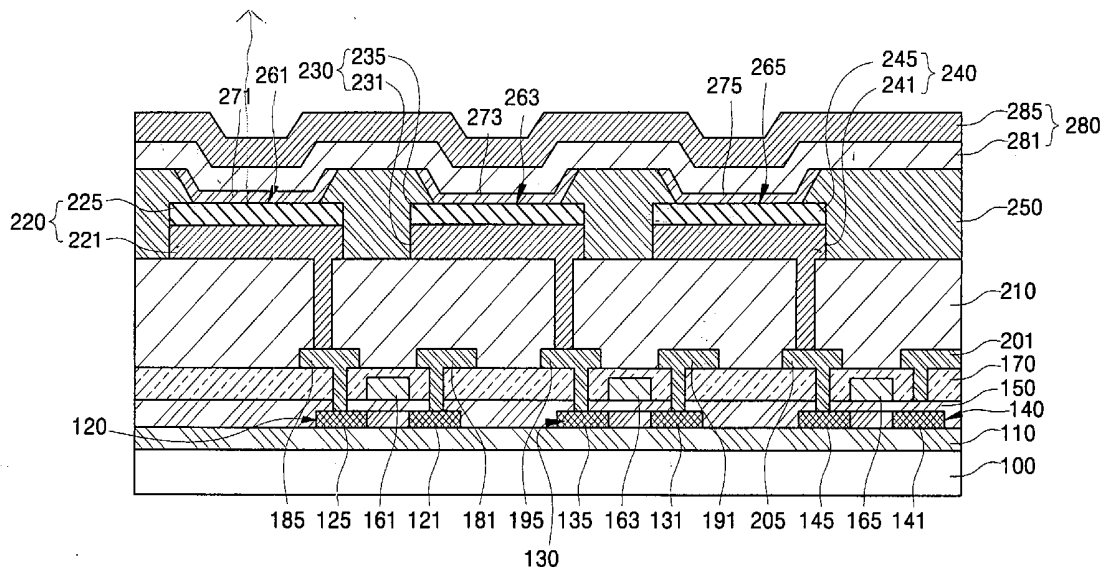

FIG. 1

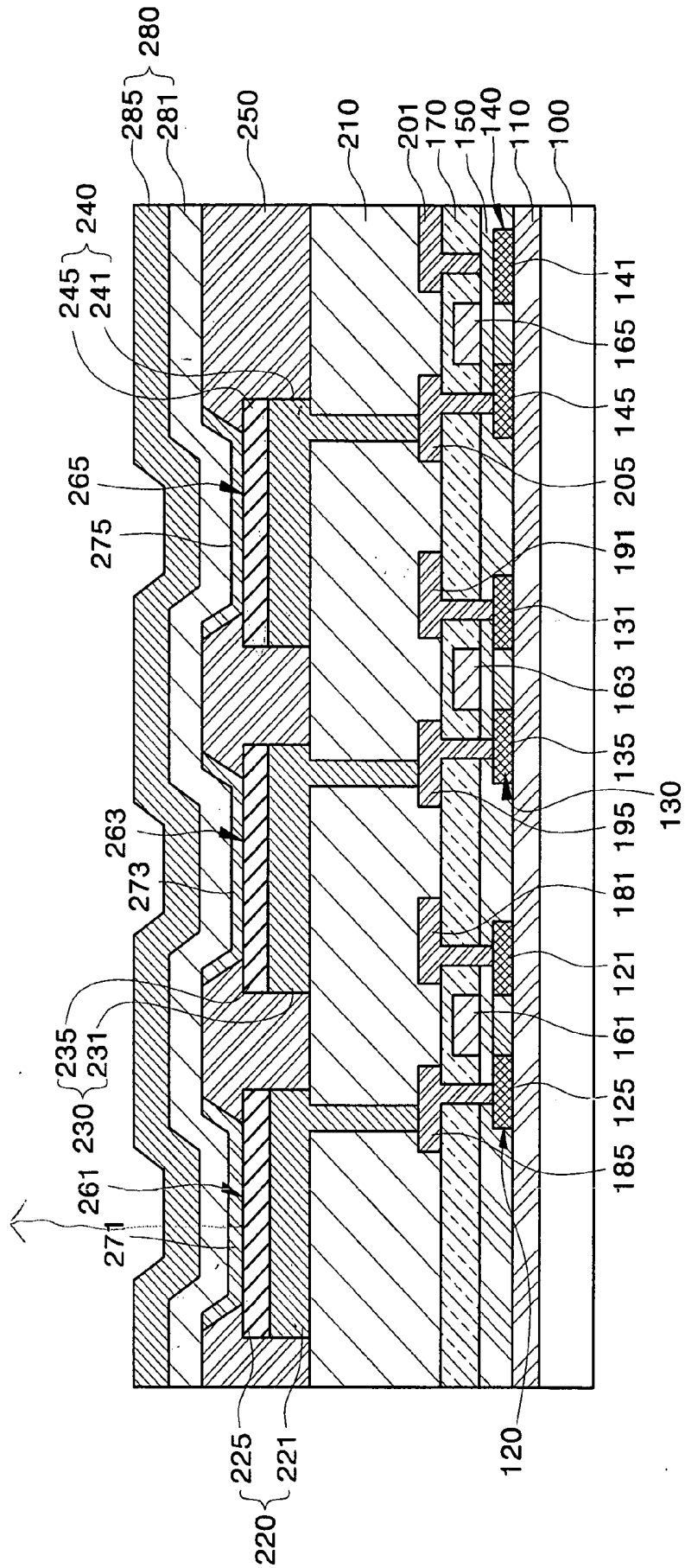

FIG. 2

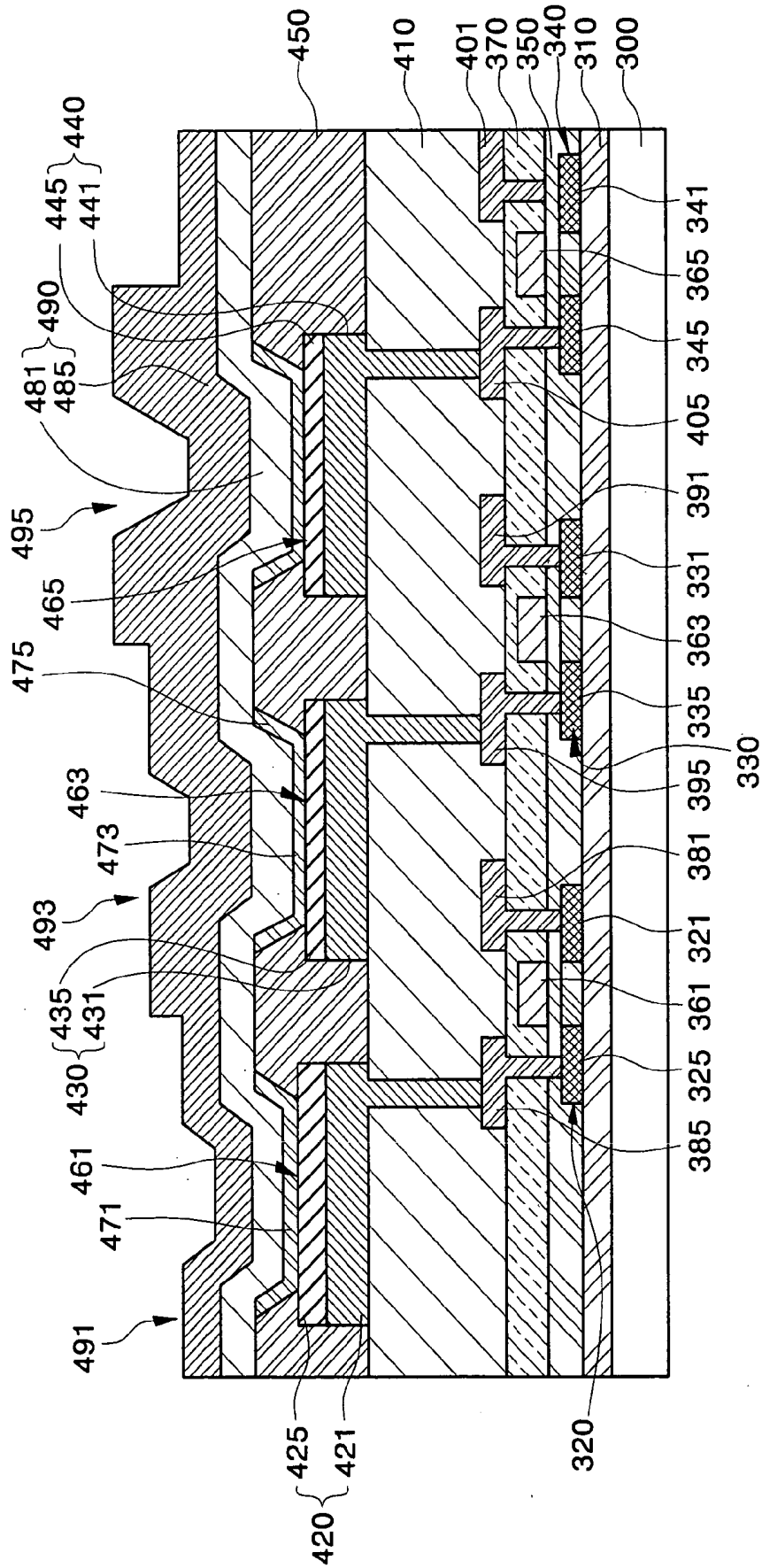

FIG. 3A

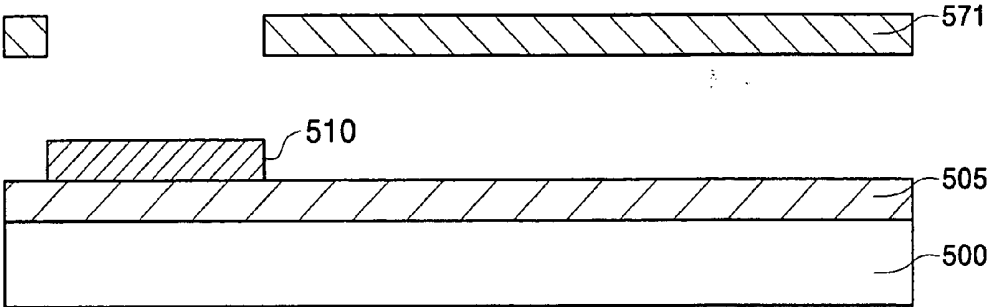

FIG. 3B

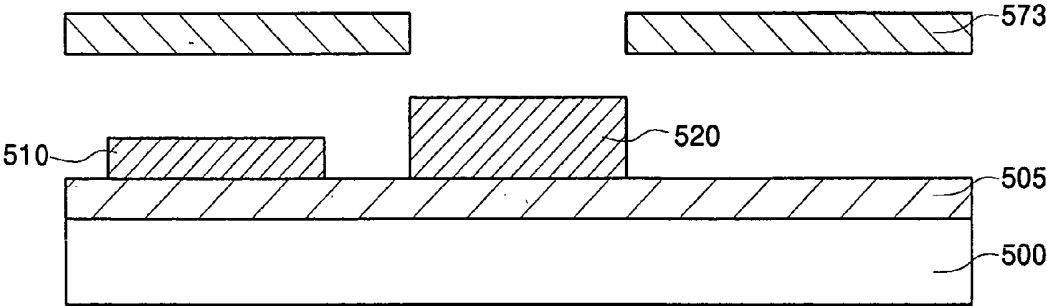

FIG. 3C

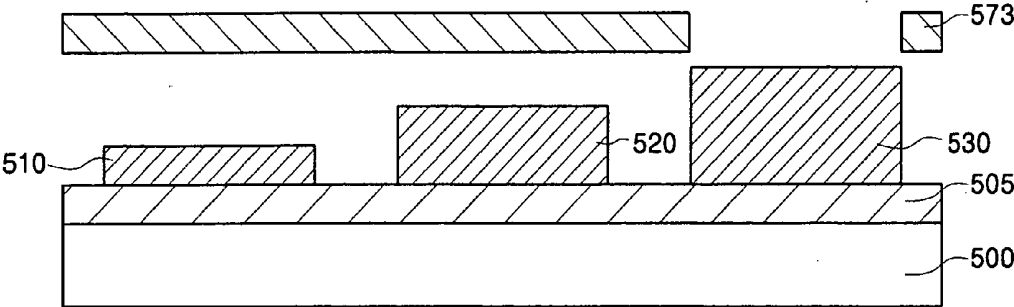

FIG. 3D

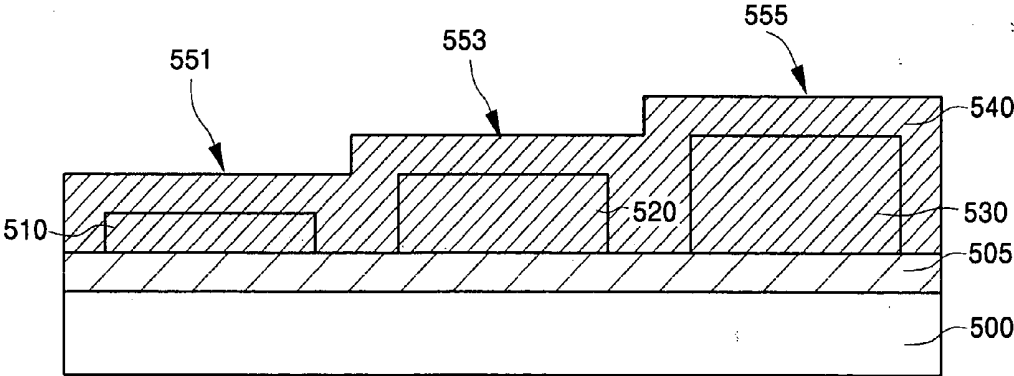

FIG. 4A

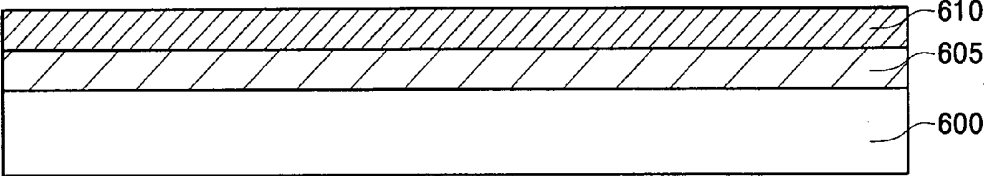

FIG. 4B

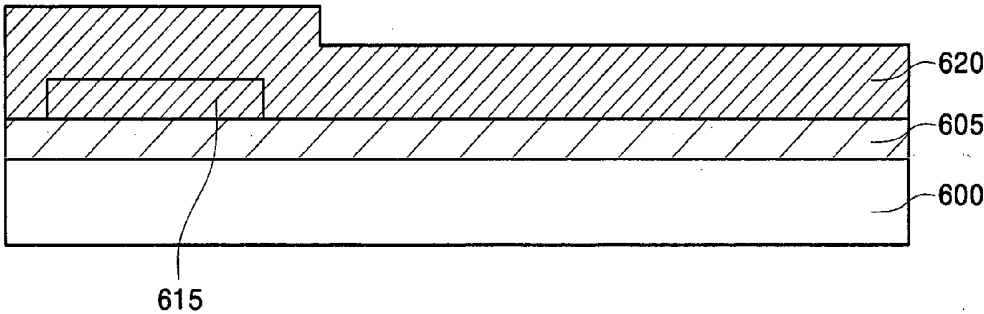

FIG. 4C

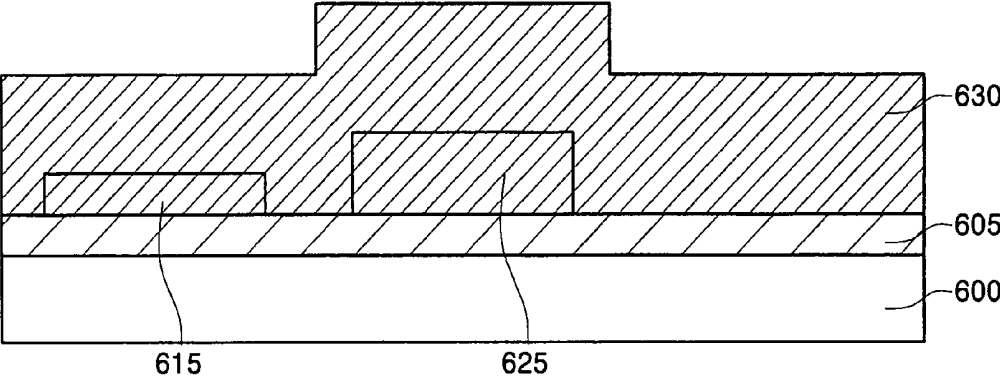

FIG. 4D

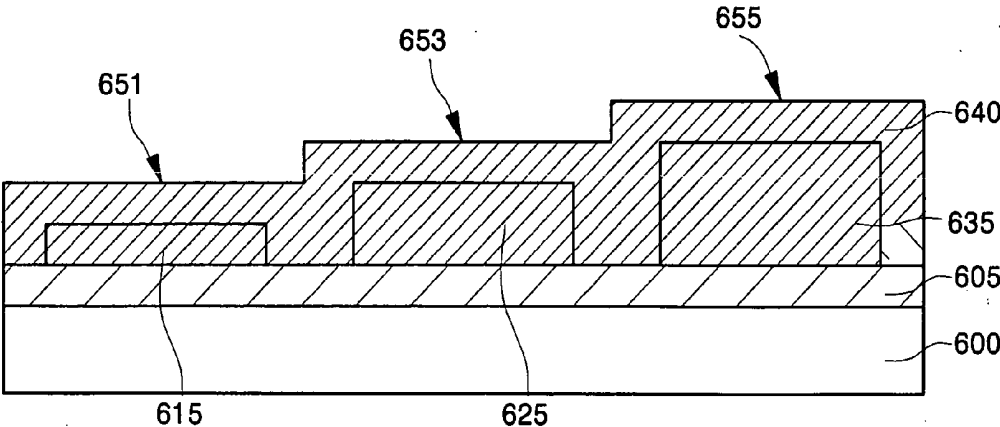

FIG. 5A

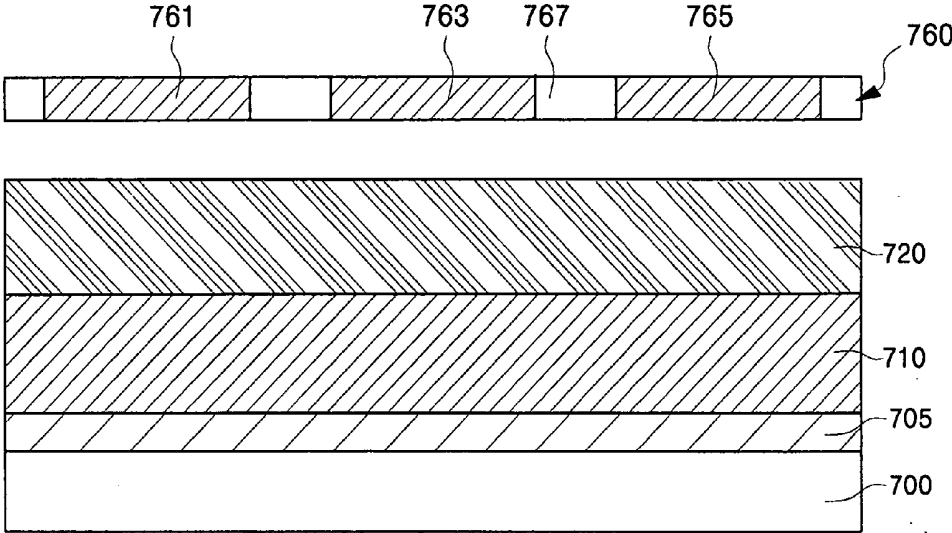

FIG. 5B

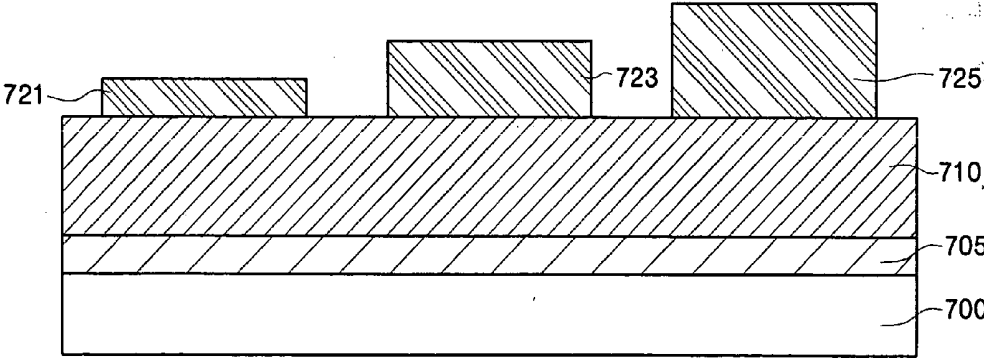

FIG. 5C

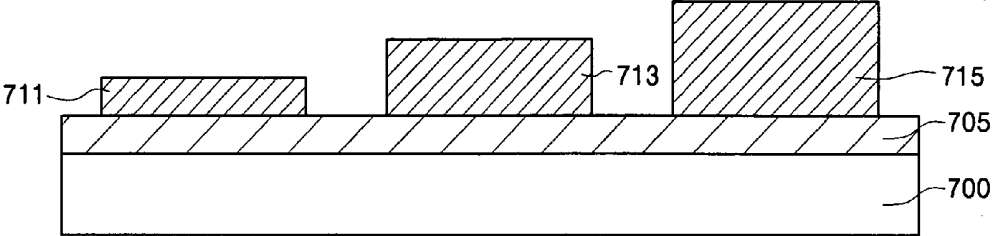

FIG. 5D

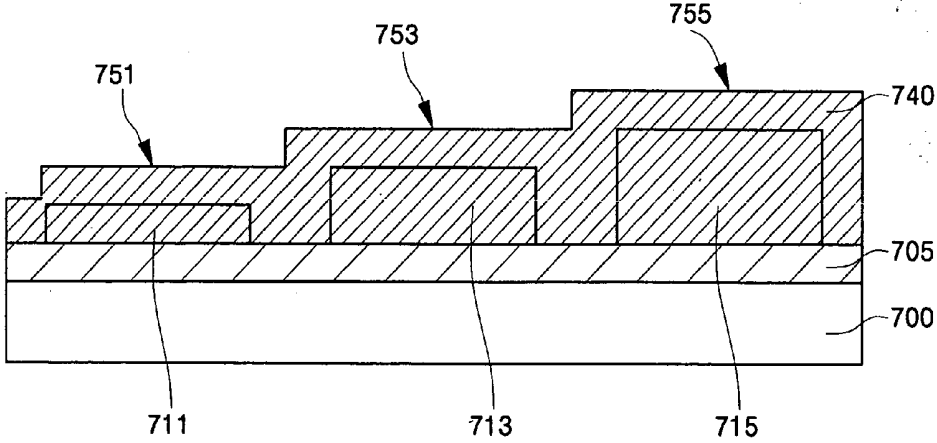

FIG. 6

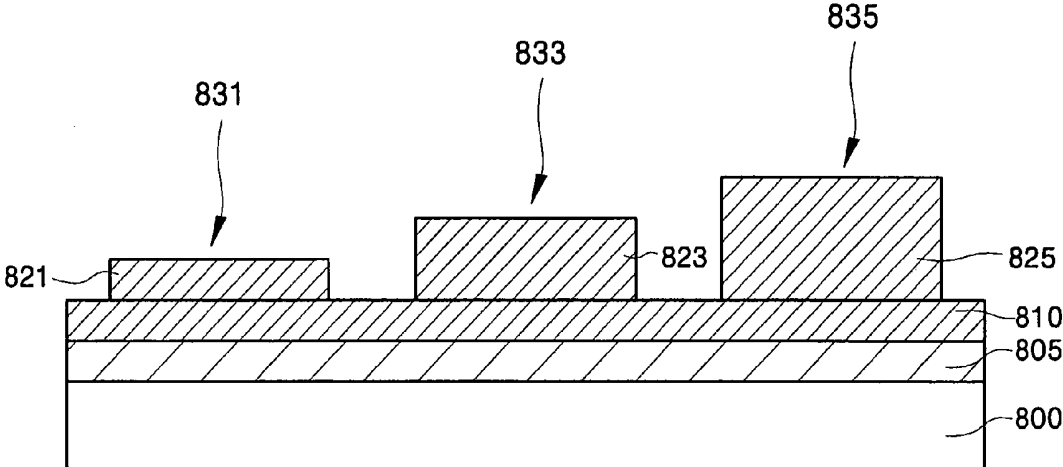

FIG. 7

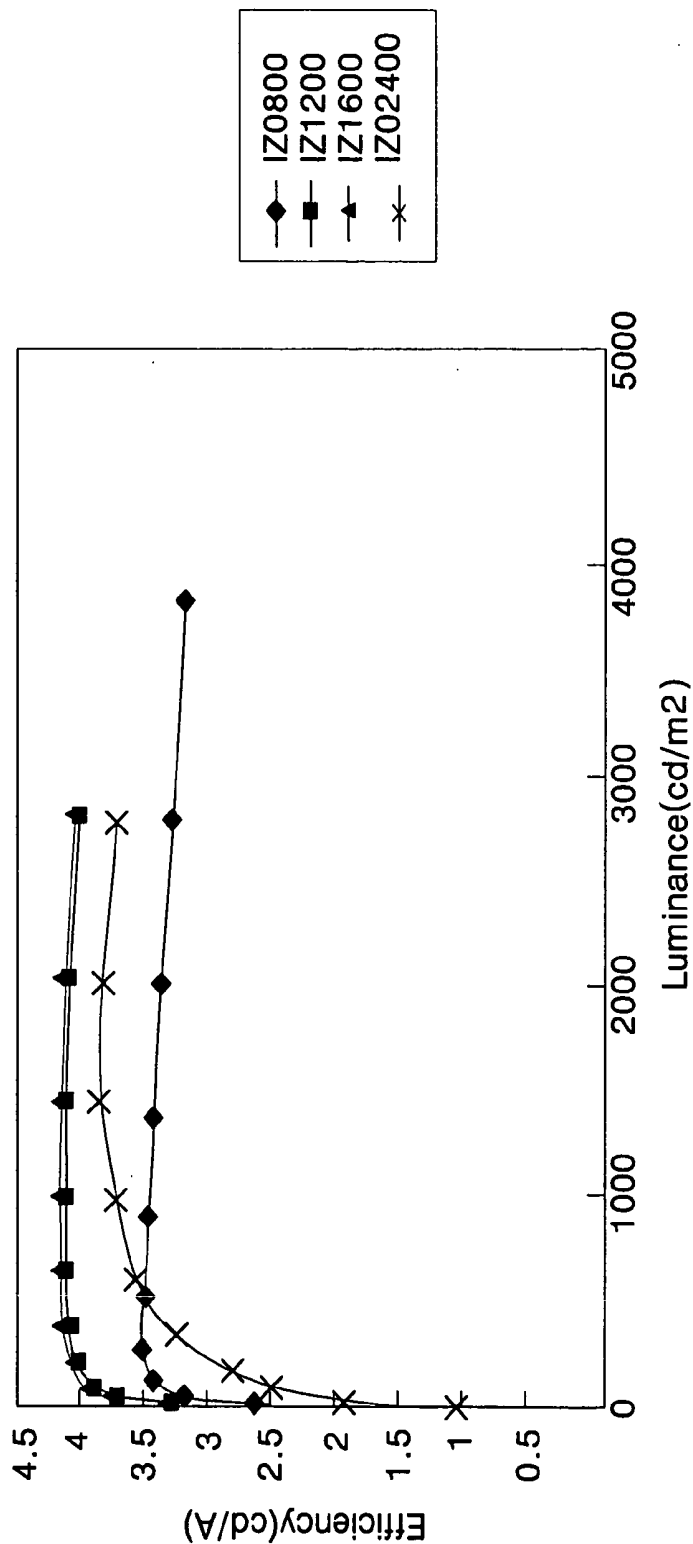

FIG. 8

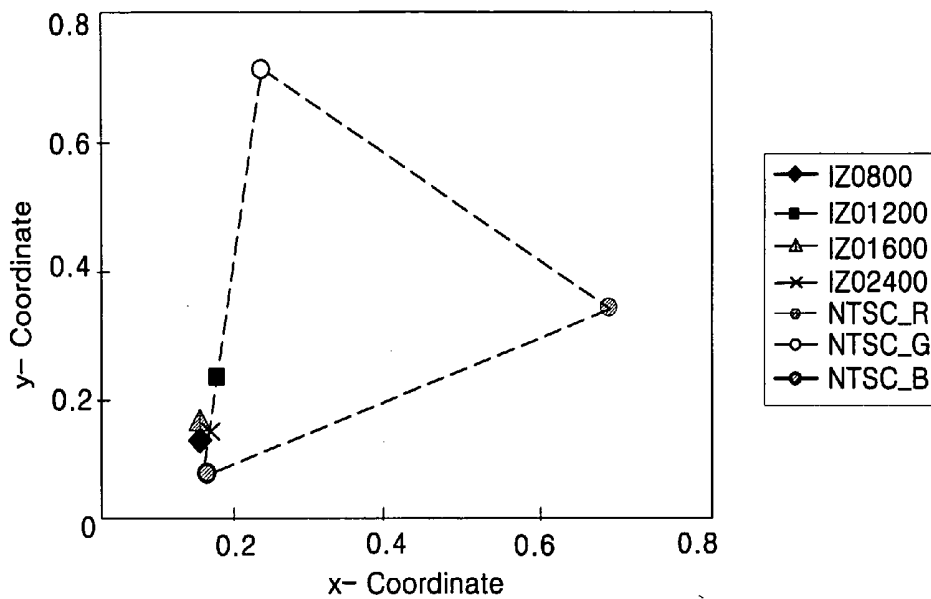

FIG. 9

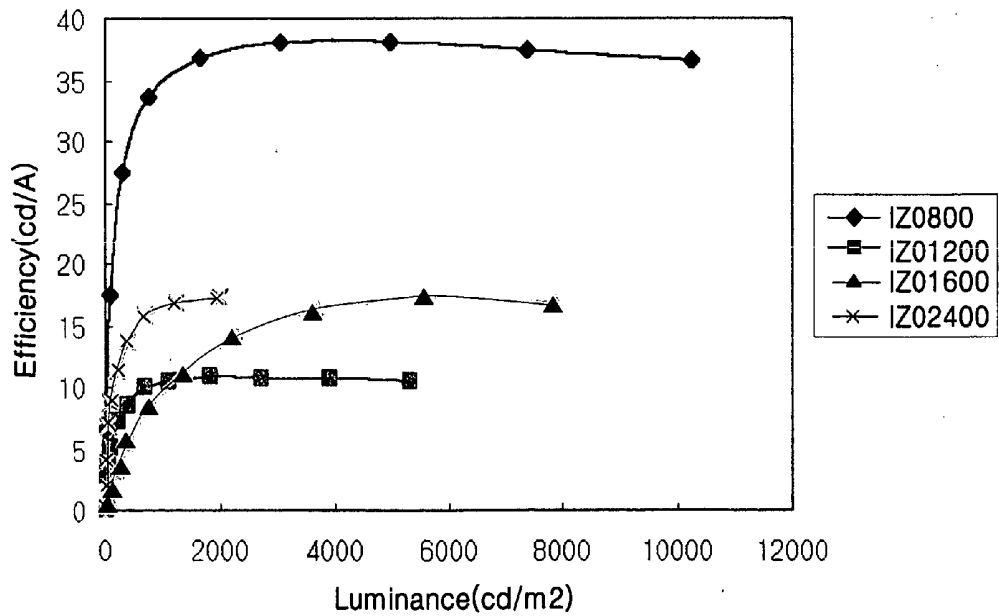

FIG. 10

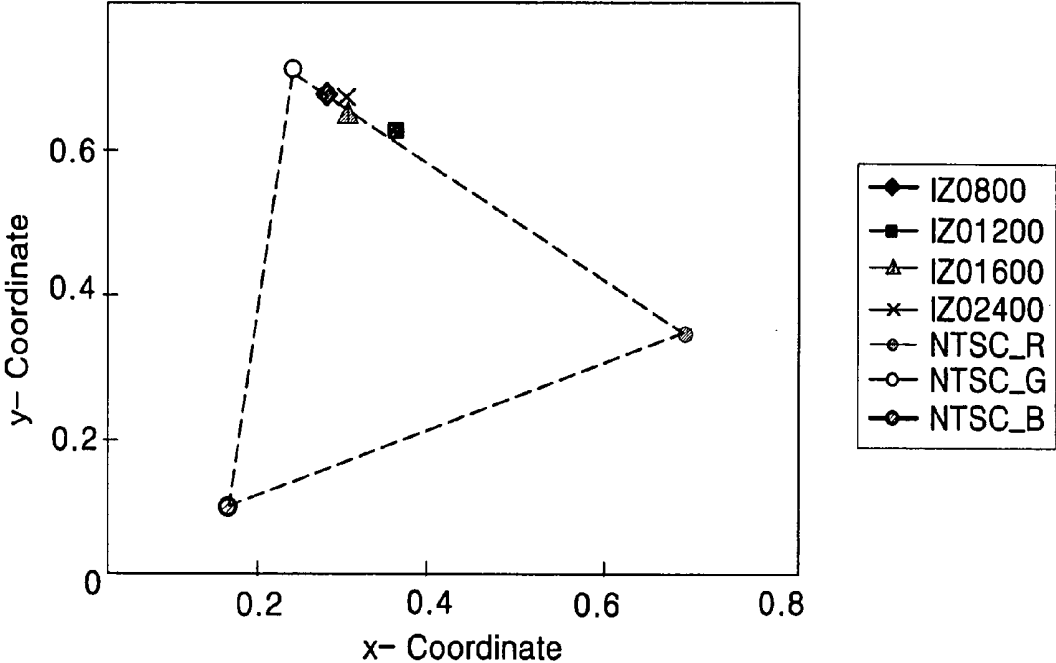

FIG. 11

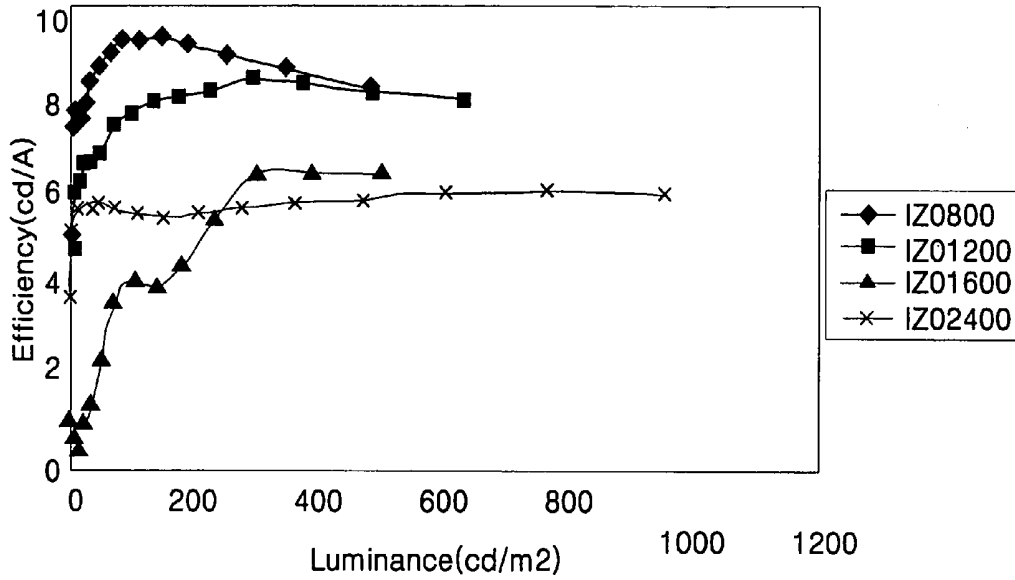

FIG. 12

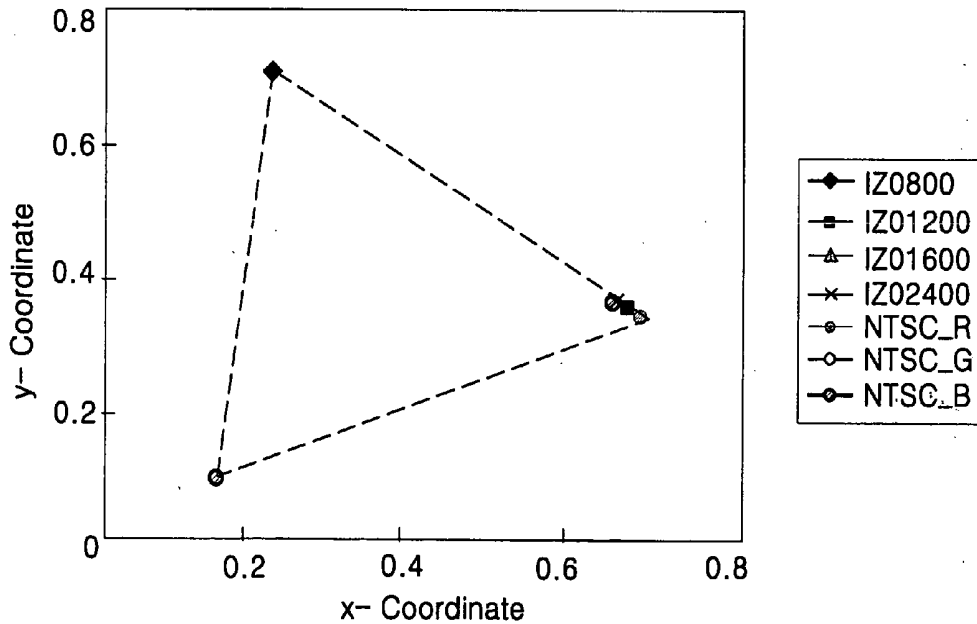
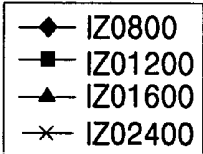
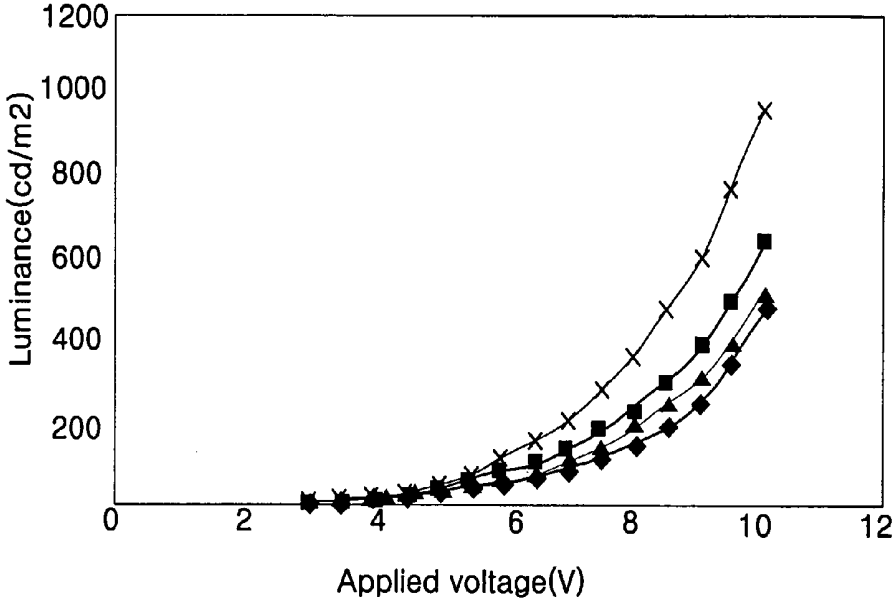

FIG. 13



FLAT PANEL DISPLAY WITH HIGH EFFICIENCY AND METHOD OF FABRICATING THE SAME

CROSS-REFERENCE TO RELATED APPLICATION

[0001] This application claims priority of Korean Patent Application No. 10-2003-51811, filed on Jul. 26, 2003, and which is hereby incorporated by reference.

BACKGROUND OF THE INVENTION

[0002] 1. Field of the Invention

[0003] The present invention generally relates to a flat panel display and, more particularly, to a flat panel display having a high efficiency in which a cathode electrode has a different thickness for each of red (R), green (G), and blue (B) pixels, and a method of fabricating the same.

[0004] 2. Description of the Related Art

[0005] A conventional active matrix organic light emitting device includes an anode electrode which is connected to a thin film transistor, a cathode electrode, and a red (R), green (G), or blue (B) organic thin film layer formed therebetween. The organic thin film layer can include multiple layers. Examples of such layers include a hole injecting layer, a hole transporting layer, R, G, B organic emission layers, a hole blocking layer, an electron transporting layer, and an electron injecting layer.

[0006] The cathode electrode typically uses a metal electrode, which may be formed of metals such as aluminum (Al), or metals alloys such as Magnesium (Mg)-Silver (Ag). These and other metals and metal alloys facilitate electron transportation and at the same time, protect the underlying organic thin film layer. To render the display more stable and less susceptible to electromagnetic interference, a two-layer cathode electrode is typically used. However it is nearly impossible to obtain optimized efficiency and color coordinates because the conventional cathode electrode is typically formed in a uniform thickness for each of the R, G, or B pixels.

[0007] FIG. 1 shows a cross-sectional view of a conventional active matrix organic light emitting device which includes a conventional two-layer structured cathode electrode.

[0008] Thin film transistors 120, 130, 140 for R, G, B unit pixels 101, 103, and 105, respectively, are formed on a buffer layer 110 of a substrate 100. The thin film transistors 120, 130, 140 include source/drain regions 121 and 125, 131 and 135, and 141 and 145, gates 161, 163, 165 formed on a gate insulating layer 150, and source/drain electrodes 181 and 185, 191 and 195, and 201 and 205 formed on an insulating interlayer layer 170.

[0009] Anode electrodes, 220, 230 and 240, which are lower electrodes for the R, G, B unit pixels, are formed on a passivation layer 210 and are connected to one of the drain electrodes 185, 195, and 205, respectively, through via holes 107, 109, 111.

[0010] Further, a pixel defining layer 250 for isolating respective R, G, B unit pixels 101, 103, 105 is formed on the passivation layer 210. R, G, B organic thin film layers 271, 273, 275, respectively, are formed on the anode electrodes

220, 230, 240 for the R, G, B unit pixels 101, 103, 105, respectively, exposed through openings 261, 263, 265 of the pixel defining layer 250. A cathode electrode 280 is formed as an upper electrode on an entire surface of the substrate 100.

[0011] The anode electrodes 220, 230, 240 include first anode electrodes 221, 231, 241, respectively, each having high reflectivity, and second anode electrodes 225, 235, 245 for adjusting a work function. The anode electrodes 220, 230, 240 have equal thicknesses for each of the R, G, B unit pixels 101, 103, 105, respectively.

[0012] The cathode electrode 280 is formed of a first cathode electrode 281 constructed of a metal or metal alloy and a second cathode electrode 283 constructed of a transparent conductive layer having excellent stability, and is formed on the entire surface of the substrate 100 with a uniform thickness. Exemplary metals and metal alloys commonly used include Lithium Fluoride (LiF) or Magnesium and Silver alloys (Mg:Ag). Exemplary transparent conductive materials include Indium tin oxide (ITO) and Indium zinc oxide (IZO).

SUMMARY OF THE INVENTION

[0013] An organic light emitting device is disclosed. In one embodiment, the organic light emitting device includes red (R), green (G) and blue (B) lower electrodes formed on a substrate. R, G, B organic thin film layers are formed on the R, G, B lower electrodes, respectively. Additionally, an upper single or multilayer electrode is formed over the substrate. Portions of the upper electrode that correspond to the R, G, B organic thin film layers, respectively, are formed to each have a different thickness. Various methods for forming the upper electrode using a fine metal mask, a halftone mask, and single and multiple photolithography processes are also disclosed. In particular, a method of fabricating a highly efficient flat panel display capable of obtaining optimized efficiency and color coordinates by forming a cathode electrode having a different thickness for each of R, G, B unit pixels is also disclosed.

BRIEF DESCRIPTION OF THE DRAWINGS

[0014] Various features and advantages of the present invention will become more apparent to those of ordinary skill in the art by describing in detail embodiments thereof with reference to the accompanying drawings in which:

[0015] FIG. 1 is a cross-sectional view of a conventional top-emitting organic light emitting device;

[0016] FIG. 2 is a cross-sectional view of an organic, top, light emitting device configured in accordance with an embodiment of the present invention;

[0017] FIGS. 3A to 3D are sequential cross-sectional views illustrating a method of forming in an organic light emitting in which a device a cathode electrode has a different thickness for each of R, G, B, in accordance with a first embodiment of the present invention;

[0018] FIGS. 4A to 4D are sequential cross-sectional views illustrating a method of forming, in an organic light emitting device, a cathode electrode having a different thickness for each of R, G, B, in accordance with a second method of the present invention,

[0019] FIGS. 5A to 5D are sequential cross-sectional views illustrating a method of forming, in an organic light emitting device, a cathode electrode having a different thickness for each of R, G, B, in accordance with a third method of the present invention;

[0020] FIG. 6 is a cross-sectional view illustrating a method of forming, in an organic light emitting device, a cathode electrode having a different thicknesses for each of R, G, B, in accordance with a fourth embodiment of the present invention;

[0021] FIG. 7 illustrates blue (B) luminous efficiency depending on a thickness of a cathode electrode in an organic light emitting device configured in accordance with an embodiment of the present invention;

[0022] FIG. 8 illustrates blue (B) color coordinates depending on a thickness of a cathode electrode in an organic light emitting device, configured in accordance with an embodiment of the present invention;

[0023] FIG. 9 illustrates green (G) luminous efficiency depending on a thickness of a cathode electrode in an organic light emitting device, configured in accordance with an embodiment of the present invention;

[0024] FIG. 10 illustrates green (G) color coordinates depending on a thickness of a cathode electrode in an organic light emitting device, configured in accordance with an embodiment of the present invention;

[0025] FIG. 11 illustrates red (R) luminous efficiency depending on a thickness of a cathode electrode in an organic light emitting device, configured in accordance with an embodiment of the present invention;

[0026] FIG. 12 illustrates red (R) color coordinates depending on a thickness of a cathode electrode in an organic light emitting device, configured in accordance with an embodiment of the present invention; and

[0027] FIG. 13 illustrates red (R) luminance depending on an applied voltage in an organic light emitting device, configured in accordance with an embodiment of the present invention.

[0028] The thicknesses of the layers and regions illustrated in the figures are exaggerated for clarity of explanation.

DETAILED DESCRIPTION OF THE INVENTION

[0029] Exemplary embodiments of the present invention will now be described more fully with reference to the accompanying drawings. This invention may, however, be embodied in different forms and should not be construed as limited to the embodiments set forth herein. Rather, these embodiments are provided so that this disclosure will be thorough and complete, and will fully convey the scope of the invention to those skilled in the art.

[0030] An exemplary embodiment of the present invention provides an organic light emitting device having R, G, B lower electrodes formed on a substrate, R, G, B organic thin film layers (e.g. emission layers) formed on the R, G, B lower electrodes, respectively, and an upper electrode formed over the substrate, wherein at least one of the R, G,

B organic thin film layers of the upper electrode has a different thickness from the other R, G, B organic thin film layers.

[0031] In a particular exemplary embodiment, the upper electrode includes a first upper electrode material formed on the substrate and a second upper electrode material formed on the first upper electrode material. Such that a portion of the second upper electrode material that corresponds to a R, G or B organic thin film layer of the lower R, G, and B electrodes has a different thickness from its counterpart portions. The first upper electrode material may be formed of one or more metals and the second upper electrode material may be formed of one or more transparent conductive materials. Exemplary metals and metal alloys include LiF and Mg:Ag and the like. Exemplary transparent conductive materials include ITO, IZO, and the like.

[0032] On one exemplary embodiment, the second upper electrode material is formed in a thickness of approximately 800 Å to approximately 2400 Å, because a thickness of approximately 800 Å to approximately 1600 Å provides high luminous efficiency, and a thickness of approximately 800 Å—approximately 2400 Å provides high color purity. A portion corresponding to an R organic thin film layer, of the second upper electrode material, preferably has a thickness of approximately 1200 Å or approximately 2400 Å; a portion corresponding to an G organic thin film layer preferably has a thickness of approximately 800 Å, and a portion corresponding to a B organic thin film layer preferably has a thickness of approximately 1600 Å.

[0033] In another exemplary embodiment, the upper electrode includes a first upper electrode material formed on the substrate, and a second upper electrode material on the first upper electrode material, wherein portions corresponding to the R, G, B organic thin film emission layers have different thicknesses. In this embodiment, the second upper electrode material includes first layers for the R, G, B unit pixels independently formed having a different thickness on respective portions of the first upper electrode material corresponding to the R, G, B emission layers, and a second layer formed in a uniform thickness on the first layer and the first upper electrode material.

[0034] In another exemplary embodiment, the upper electrode includes a first upper electrode material formed on the substrate, and a second upper electrode material on the first upper electrode material, wherein portions corresponding to the R, G, B emission layers have different thicknesses. The second upper electrode material includes a first layer of uniform thickness formed on the first upper electrode material, and second layers for the R, G, B unit pixels having different thicknesses on respective portions of the first layer corresponding to the R, G, B emission layers.

[0035] In this exemplary configuration, the first upper electrode material is made of one or more metals or metal alloys, such as, but not limited to LiF, Mg:Ag, and the like, and the second upper electrode material is made of one or more transparent conductive materials such as, but not limited to, IZO and ITO, respectively. The cumulative thickness of the first layer and the second layer of the second upper electrode material is approximately 800 Å to approximately 2400 Å.

[0036] Moreover, another exemplary embodiment of the present invention provides a method of forming an organic

light emitting device. In this method R, G, B unit pixels, including their corresponding R, G, B lower electrodes and their corresponding R, G, and B organic film layers, are formed on a substrate. An upper electrode having portions of varying thickness that correspond to the R, G, and B emission layers is then formed over the substrate. Method steps may include, inter alia, forming the upper electrode, (e.g., forming a first upper electrode material on the substrate) and forming a second upper electrode material on the first upper electrode material to have a different thickness for each of the corresponding R, G, B emission layers. In one embodiment, forming the second upper electrode material may include forming on portions of the first upper electrode material corresponding to the R, G, B emission layers a first layer, a portion or portion of which has a different thickness for each of the corresponding R, G, B emission layers; and forming a second layer of uniform thickness on the first layer and the first upper electrode material.

[0037] The first layer of the second upper electrode material is formed independently, using a fine metal mask, by depositing the second upper electrode material in such a manner that portions of the material have a different thickness for each of the corresponding R, G, B emission layers. Alternatively, the first layer may be formed and independently patterned to have a different thickness for each of the corresponding R, G, B emission layers using a three-time repetition of a photolithography process. Alternatively, the first layer may be formed using a single photolithography process that uses a half-tone mask to pattern portions of the first layer material to have a different thickness for each of the corresponding R, G, and B emission layers.

[0038] In another exemplary embodiment, forming the second electrode material on the first electrode material may include forming a first layer in a uniform thickness on the first upper electrode material and forming a second layer on the first layer such that portions to the second layer corresponding to their respective R, G, B emission layers each have a different thickness.

[0039] As with the first layer, the second layer of the second upper electrode material may be formed to have portions of varying thickness using a fine metal mask, thrice-repeated photolithography process, single photolithography process using a half-tone mask, or like material forming process.

[0040] FIG. 2 shows a cross-sectional view of an organic, active matrix, light emitting device 301, including a two-layer structured cathode electrode, configured in accordance with an embodiment of the present invention.

[0041] Referring to FIG. 2, thin film transistors configured in R, G, B unit pixels are formed on a buffer layer 310 of an substrate 300. The respective R, G, and B thin film transistors include semiconductor layers 320, 330 and 340 formed on the buffer layer 310, each transistor including source/drain regions 321 and 325, 331 and 335, and 341 and 345, gate electrodes 361, 363 and 365 formed on a gate insulating layer 350 on the respective semiconductor layers 320, 330 and 340, and source/drain electrodes 381 and 385, 391 and 395, and 401 and 405 formed on an insulating layer 370, and connected to the source/drain regions 321 and 325, 331 and 335, and 341 and 345.

[0042] Anode electrodes 420, 430 and 440, which are lower electrodes for the R, G, B unit pixels, 491, 493, 495,

respectively, are each connected to one of the source/drain electrodes 381 and 385, 391 and 395, and 401 and 405 of the respective R, G, and B thin film transistors. For example, the drain electrodes 385, 395 and 405, are formed on a passivation layer 410. Although this exemplary embodiment of the invention illustrates the respective anode electrodes 420, 430, 440 as having a laminate structure of metal materials 421, 431, 441 and transparent conductive materials 425, 435, 445, the anode electrodes are necessarily not limited to such a configuration, but may be formed into a single layer or multi-layer structure.

[0043] A pixel defining layer 450 is formed on the passivation layer 410 for isolating the R, G, B unit pixels 491, 493, 495. R, G, B organic thin film layers 471, 473, 475, respectively, are formed in openings 461, 463, 465 of the anode electrodes 420, 430, 440, respectively, which are defined by the pixel defining layer 450. A cathode electrode 490 is formed over the entire surface of the substrate 300, and has a different thickness for each of the R, G, B unit pixels 491, 493, 495. Each of the organic thin film layers 471, 473, 475 includes at least one organic thin film layer. Depending on the embodiment, the organic thin film layer may be an electron hole injecting layer, an electron hole transporting layer, R, G, B organic emission layers, an electron hole blocking layer, an electron transporting layer, an electron injecting layer, or like layers.

[0044] The cathode electrode 490 includes a first cathode electrode material 481 formed over the entire surface of the substrate 300 and having a uniform thickness for each of the R, G, B unit pixels 491, 493, 495, and a second cathode electrode material 485 formed on the first cathode electrode material 481 and having a different thickness for each of the R, G, B unit pixels 491, 493, 495. In an exemplary embodiment, the first cathode electrode material 481 is made of a metal or metal alloy such as LiF or Mg:Ag or the like; and the second cathode electrode material 485 is composed of a transparent conductive material such as IZO or ITO, or the like.

[0045] If IZO is used to form the second cathode electrode material 485 of the cathode electrode 490, the luminous efficiency and color coordinates of blue (B) color vary depending on the thickness of the IZO layer. These variations are described below and shown in Table 1 and FIGS. 7 and 8, respectively.

TABLE 1

IZO layer thickness	Blue luminous efficiency	Blue color coordinates
800 Å	3.4cd/A	0.13, 0.13
1200 Å	4.1cd/A	0.15, 0.22
1600 Å	4.1cd/A	0.12, 0.15
2400 Å	3.8cd/A	0.13, 0.13
NTSC system criterion		0.14, 0.08

[0046] As used above, the NTSC (national television systems committee) system means a color TV standard system. However, other TV or media systems may be supported.

[0047] Referring to Table 1 and FIGS. 7 and 8, if the IZO layer used as the second cathode electrode material 485 of the cathode electrode 490 is deposited in a thickness of approximately 800 Å to approximately 2400 Å, a high

luminous efficiency of B color can be obtained. In particular, if the IZO is deposited to a thickness of approximately 1200 Å to approximately 1600 Å, a high luminous efficiency of 4 cd/A can be obtained. Furthermore, if the IZO layer is deposited in a thickness of approximately 800 Å to approximately 2400 Å, a high color purity of B color can be obtained. Such color purity, compared to that of the NTSC system, in the IZO layer thickness of approximately 1600 Å is superior to that in the IZO layer thickness of approximately 1200 Å. Thus, in one embodiment, the second cathode electrode material **485**, corresponding to a blue emission layer, of the cathode electrode **490** has a thickness of approximately 1600 Å in order to meet both high luminous efficiency and color purity for B color.

[0048] If IZO is used to form the second cathode electrode material **485** of the cathode electrode **490**, the luminous efficiency and color coordinates of green (G) color vary depending on the thickness of the IZO layer. These variations are described and shown in Table 2 and FIGS. 9 and 10, respectively.

TABLE 2

IZO layer thickness	Green luminous efficiency	Green color coordinates
800 Å	33.6cd/A	0.26, 0.67
1200 Å	9.9cd/A	0.34, 0.61
1600 Å	5.6cd/A	0.28, 0.64
2400 Å	15.8cd/A	0.28, 0.67
NTSC criterion		0.21, 0.71

[0049] Referring to Table 2 and FIGS. 9 and 10, if the IZO layer used as the second cathode electrode material **485** of the cathode electrode **490** is deposited in the thickness of approximately 800 Å to approximately 2400 Å, a high luminous efficiency and color purity of G color can be obtained. Superior efficiency is obtained when the IZO layer, which is the second cathode electrode material **485**, has a thickness of approximately 800 Å. Additionally, the color purity, compared to that of the NTSC, in the IZO layer thickness of approximately 800 Å or approximately 2400 Å is superior to an IZO layer deposited to thickness of approximately 1200 Å or approximately 1600 Å. Thus, in one embodiment, the second cathode electrode material **485**, corresponding to a green (G) emission layer, of the cathode electrode **490** has a layer thickness of approximately 800 Å in order to meet both high luminous efficiency and color purity for green color.

[0050] If IZO is used to form the second cathode electrode material **485** of the cathode electrode **490**, the luminous efficiency and color coordinates of red (R) color vary depending on the IZO layer thickness. These variations are described below and shown in Table 3 and FIGS. 11 and 12, respectively.

TABLE 3

IZO layer thickness	Red luminous efficiency	Red color coordinates
800 Å	8.3cd/A @400nit	0.64, 0.35
1200 Å	8.1cd/A @400nit	0.66, 0.34
1600 Å	6.4cd/A	0.66, 0.34
2400 Å	5.8cd/A	0.64, 0.34
NTSC criterion		0.67, 0.33

[0051] Referring to Table 3 and FIGS. 11 and 12, if the IZO layer used as the second cathode electrode material **485** of the cathode electrode **490** is deposited in the thickness of approximately 800 Å to approximately 2400 Å, a high luminous efficiency and color purity with respect to the red color can be obtained. In one embodiment, the IZO layer being the second cathode electrode material **485** has a thickness of approximately 1200 Å or approximately 2400 Å, from an efficiency aspect, for required luminance. Superior color purity, as compared to the NTSC, is excellent for the IZO layer thickness of approximately 800 Å, 1200 Å, 1600 Å and 2400 Å. Thus, in one embodiment, the second cathode electrode material **485**, corresponding to the red (R) emission layer, of the cathode electrode **490** has a layer thickness of approximately 1200 Å or approximately 2400 Å in order to meet high luminous efficiency and color purity with respect to the red color.

[0052] In an exemplary embodiment, as described above, it is preferable that the second cathode electrode material **485** of the cathode electrode **490** be deposited in a thickness of approximately 800 Å to approximately 2400 Å. In such an embodiment, it is also preferable that the second cathode electrode material **485** be deposited in the thickness of approximately 800 Å to approximately 1600 Å to obtain high luminous efficiency, and that the second cathode electrode material **485** be deposited in the thickness of approximately 800 Å to approximately 2400 Å to obtain high color purity.

[0053] FIG. 13 illustrates red (R) luminance depending on an amount of voltage applied in an organic light emitting device configured in accordance with an embodiment of the present invention. The red (R) luminance increases as the applied voltage increases. If IZO is used as the second transparent conductive layer of the second cathode electrode material, a high R luminance is obtained when the IZO layer thickness is approximately 1200 Å or approximately 2400 Å.

[0054] Turning now to the methods of the present invention.

[0055] FIGS. 3A to 3D are cross-sectional views illustrating a method of forming a cathode electrode having a different thickness in an organic light emitting device in accordance with a first method of the present invention. FIGS. 3A to 3D only show a cathode electrode formed on a substrate **500**.

[0056] In this first embodiment the cathode electrode is formed by depositing a second cathode electrode material using a fine metal mask in such a manner that portions of the second cathode electrode material have a different thickness for each of corresponding R, G, B unit pixels.

[0057] As shown in FIG. 3A, a first cathode electrode material **505**, such as LiF or Mg:Ag, is formed on a substrate **500**. Then, using a fine metal mask **571**, a first transparent conductive layer **510** for an R unit pixel is formed on a portion of the first cathode electrode material **505** that corresponds to an R organic emission layer (not shown). As shown in FIG. 3B, a fine metal mask **573** is used to form a first transparent conductive layer **520** for a G unit pixel on a portion of the first cathode electrode material **505** that corresponds to a G organic emission layer (not shown).

[0058] Subsequently, as shown in FIG. 3C, a first transparent conductive layer **530** for a B unit pixel is formed on

a portion of the first cathode electrode material **505** that corresponds to a B organic emission layer (not shown), using a fine metal mask **573**. Finally, as shown in **FIG. 3D**, a second transparent conductive layer **540** is formed in a uniform thickness on the first transparent conductive layers **510, 520, 530** for the R, G, and B unit pixels **551, 553, 555**, and the first cathode electrode material **505**.

[0059] Thus in one embodiment, the second cathode electrode material includes the first transparent conductive layers **510, 520, 530** formed independently to have a different thickness for each of the R, G, B unit pixels **551, 553, 555**; while the second transparent conductive layer **540** is formed to have a uniform thickness. The cathode electrode, therefore, is composed of the first cathode electrode material **505** having a uniform thickness on the substrate **500** and of the second cathode electrode material having portion of a different thickness for each of corresponding R, G, B unit pixels **551, 553** and **555**.

[0060] In the exemplary just described, the thickness of the second cathode electrode material, (namely, a sum of the thickness of the first transparent conductive layers **510, 520, 530** and the thickness of the second transparent conductive material **540**) is approximately 800 Å to approximately 2400 Å. In this embodiment, the thickness of the portion of the second cathode electrode material corresponding to the R unit pixel that corresponds to the R organic emission layer, (namely, the sum of the thickness of the first transparent conductive layer **510** and the thickness of the second transparent conductive layer **540**) is approximately 1200 Å or approximately 2400 Å in order to obtain high luminous efficiency and color purity for the red (R) color. The thickness of the portion of the second cathode electrode material corresponding to the G unit pixel that corresponds to the G organic emission layer, (namely, the sum of the thickness of the first transparent conductive layer **520** and the thickness of the second transparent conductive layer **540**) is approximately 800 Å in order to obtain high luminous efficiency and color purity for the green (G) color. The thickness of the second cathode electrode material for the B unit pixel that corresponds to the B organic emission layer, (namely, the sum of the thickness of the first transparent conductive layer **530** and the thickness of the second transparent conductive layer **540**) is approximately 1600 Å in order to obtain high luminous efficiency and color purity for the blue (B) color.

[0061] **FIGS. 4A to 4D** are cross-sectional views illustrating a second method of forming a cathode electrode having portions of different thickness in an organic light emitting device, in accordance with a second method of the present invention. These Figures only show a cathode electrode formed on a substrate **600**.

[0062] In accordance with a second embodiment, this second method of forming a cathode electrode is different from the first embodiment only in that the cathode electrode is independently patterned to include different thickness for each of the corresponding R, G, B unit pixels using a three-time repetition of a photolithography process. That is, as shown in **FIG. 4A**, a transparent conductive layer **610** is deposited in a thickness suitable for an R unit pixel on a substrate **600** on which a first cathode electrode **605** is formed. Then, as shown in **FIG. 4B**, a portion of the first transparent conductive layer **615** for the R unit pixel that corresponds to an R organic emission layer (not shown) is

formed by photolithographing the transparent conductive layer **610** using a first mask (not shown).

[0063] Subsequently, a transparent conductive layer **620** is deposited to a thickness suitable for a G unit pixel on an entire surface of the substrate **600**, and then a portion of the first transparent conductive layer **625** corresponding to the G unit pixel is formed by photolithographing the transparent conductive layer **620** using a second mask (not shown), as shown in **FIG. 4C**.

[0064] Next, a transparent conductive layer **630** is deposited over the entire surface of the substrate **600** to a thickness suitable for a B unit pixel, and then a portion of the first transparent conductive layer **635** for the B unit pixel is formed by photolithographing the transparent conductive layer **630** using a third mask (not shown). Subsequently, a second transparent conductive layer **640** is formed in a uniform thickness on the first transparent conductive layers **615, 625** and **635** and the first cathode electrode material **605**, as shown in **FIG. 4D**.

[0065] Thus, in this exemplary embodiment, the second cathode electrode material includes the first transparent conductive layers **615, 625, 635** for the R, G, B unit pixels **651, 653** and **655**, which were independently formed to have different thickness so as to correspond to the R, G, B organic emission layers. Additionally, the second transparent conductive layer **640** is formed over the entire surface of the substrate **600**. Consequently, the cathode electrode is composed of the first cathode electrode material **605** having a uniform thickness and of the second cathode electrode material, portions of which have a different thickness for each of the corresponding R, G, B unit pixels **651, 653** and **655**.

[0066] **FIGS. 5A to 5D** are cross-sectional views illustrating another exemplary method of forming a cathode electrode in an organic light emitting device to have portions of different thickness, in accordance with a third method of the present invention. These figures only show a cathode electrode formed on a substrate.

[0067] The method of forming a cathode electrode in accordance with the third embodiment is different from the first or second embodiment only in that portions of a cathode electrode are independently patterned to have a different thickness for each of corresponding R, G, B unit pixels using a single photolithography process which uses a halftone mask. As shown in **FIG. 5A**, a first cathode electrode material **705**, such as LiF or Mg:Ag, is formed with a uniform thickness on a substrate **700**, and a transparent conductive layer **710** is deposited on the first cathode electrode **705**. The transparent conductive layer **710** is covered with a photosensitive layer **720**. In one embodiment, the transparent conductive layer **710** is deposited to at least the same thickness as that of a portion of a second cathode electrode material corresponding a unit pixel which has the largest thickness of R, G, B unit pixels formed at a subsequent process.

[0068] Referring again to **FIG. 5A**, a halftone mask **760** is aligned to the substrate on which the photosensitive layer **720** and the transparent conductive layer **710** have been deposited, and then an exposure process is performed. The halftone mask **760** may include a transmitting pattern **767**, semi-transmitting patterns **761** and **763**, and a blocking

pattern **765**. It will be appreciated that the transmitting pattern **767** corresponds to a portion in which all the photosensitive layer will be removed to transmit all the incident light in the exposure process. The blocking pattern **765** corresponds to a portion in which the first cathode electrode of the B unit pixel will be formed, namely, a portion in which the photosensitive layer will be left as it is, to block all incident light in the exposure process. Semi-transmitting patterns **761** and **763** correspond to portions in which the first cathode electrode of the R and G unit pixels will be formed, namely those portions in which the photosensitive layer will be removed by a constant thickness to transmit only a portion of the incident light in the exposure process. The semi-transmitting pattern **761**, corresponding to the R unit pixel, of the semi-transmitting patterns **761**, **763** is formed to transmit relatively more incident light in the exposure process than the semi-transmitting pattern **763** corresponding to the G unit pixel.

[**0069**] Since the amount of the light exposed through the semi-transmitting patterns **761**, **763** and the blocking pattern **765** is different from each other when the exposure and development process are performed, photosensitive layer patterns **721**, **723**, **725** corresponding to the R, G, B unit pixels are formed to have different thicknesses from each other, as shown in **FIG. 5B**.

[**0070**] As shown in **FIG. 5C**, if the first cathode electrode material **710** is patterned using the photosensitive layer patterns **721**, **723** and **725** as masks, the first transparent conductive layers **711**, **713** and **715** for the R, G, B unit pixels will be formed to have a different thicknesses for each of the R, G, B unit pixels because the photosensitive layer patterns **721**, **723** and **725** have a different thickness for each of the R, G, B unit pixels.

[**0071**] As shown in **FIG. 5D**, a second transparent conductive layer **740** may then be formed in a uniform thickness on the first transparent conductive layers **711**, **713**, **715** (that respectively correspond to the R, G, B unit pixels) and on the first cathode electrode material **705**. Thus in this embodiment, the second cathode electrode material includes the first transparent conductive layers **711**, **713**, **715**, each independently, formed to have a different thickness that corresponds to R, G, B unit pixels **751**, **753**, **755**, which have corresponding R, G, B organic thin film layers. Moreover, the second transparent conductive layer **740** in this embodiment has a uniform thickness. Consequently, the cathode electrode is composed of the first cathode electrode material **705** having a uniform thickness, and the second cathode electrode material having portions of a different thickness for each of the corresponding R, G, B unit pixels **751**, **753**, **755**.

[**0072**] **FIG. 6** is a cross-sectional view of an organic light emitting device in accordance with a fourth method of the present invention.

[**0073**] The organic light emitting device of the fourth embodiment is different from other embodiments in that in forming the second cathode electrode material, a first transparent conductive layer having a uniform thickness is formed on a first cathode electrode material, and then a second transparent conductive layer having portions of different thickness for each of corresponding R, G, B unit pixels is formed.

[**0074**] In this fourth exemplary embodiment, the cathode electrode includes a first cathode electrode material **805**

composed of a metal material such as LiF or Mg:Ag formed in a uniform thickness on a substrate **800**, and a second cathode electrode material having portions of different thickness for each of the corresponding R, G, B unit pixels that are formed on the first cathode electrode material **805**. The second cathode electrode material further includes a first transparent conductive layer **810** formed in a uniform thickness on the first cathode electrode material **805**, and a second transparent conductive layers **821**, **823**, **825** independently formed on the first transparent conductive layer **810** to have a different thickness for each of the corresponding R, G, B unit pixels **831**, **833**, **835**.

[**0075**] An exemplary method of forming a cathode electrode having portions of different thickness for each of the corresponding R, G, B unit pixels is now described.

[**0076**] To begin, the first cathode electrode material **805** is formed by depositing a metal or metal alloy material such as LiF or Mg:Ag or the like in a uniform thickness on the substrate **800**. Then the first transparent conductive layer **810** is formed by depositing a transparent conductive material such as ITO or IZO in a uniform thickness on the first cathode electrode material **805**.

[**0077**] Subsequently, the second transparent conductive layers **821**, **823**, **825** each having a different thickness for each of the corresponding R, G, B unit pixels **831**, **833** and **835** are formed on the first transparent conductive layer **810**. A method of forming the second transparent conductive layers **821**, **825**, **827** having a different thickness for each of R, G, B unit pixels **831**, **833**, **835** uses the same methods as were used to form the first transparent conductive layer of the first to third embodiments shown in **FIGS. 3A** to **3D**, **4A** to **4D**, and **5A** to **5D**.

[**0078**] Herein the cathode electrode is shown as increasing in thickness in an order of R, G, and B unit pixels. However, it is understood that the invention is not so limited. Rather than portions of the cathode electrode corresponding to the R, G, B unit pixels may be formed in any predetermined thickness suitable for luminous efficiency and color purity, as described above.

[**0079**] Although the embodiments of the present invention have been described by way of the top-emitting structure, they are also applicable to a bottom-emitting and double-side-emitting structure, where they may be used to improve high efficiency and color purity. Further, although the embodiments of the present invention have illustrated the cathode electrode as using a two-layer of a metal material and a transparent conductive layer, the present invention is applicable to all methods of forming a cathode electrode having portions of different thickness for each of the corresponding R, G, B unit pixels in order to obtain optimal color purity and is luminous efficiency for each of R, G, B unit pixels.

[**0080**] R, G, B Although the present invention has been described with reference to the preferred embodiments thereof, those skilled in the art will be understood that the present invention can be variously modified and changed without departing from the spirit and the scope of the present invention as defined by the following claims.

What is claimed is:

1. An organic light emitting device, comprising:

red (R), green (G), and blue (B) lower electrodes formed on a substrate;

- R, G, B organic thin film layers formed on the R, G, B lower electrodes, respectively; and
- an upper electrode formed over the substrate,
- wherein at least a portion of the upper electrode, corresponding to one of the R, G, B organic thin film layers, of the upper electrode has a different thickness from other portions of the upper electrode.
2. The organic light emitting device of claim 1, the upper electrode comprising:
- a first upper electrode material formed on the substrate; and
- a second upper electrode material formed on the first upper electrode material,
- wherein at least a portion of the second upper electrode material, corresponding to the R, G, B organic thin film layers, has a different thickness from other portions of the second upper electrode material.
3. The organic light emitting device of claim 2, wherein the first upper electrode material is comprised of at least one or more materials selected from LiF and Mg:Ag, and the second upper electrode material is comprised of at least one or more materials selected from IZO and ITO.
4. The organic light emitting device of claim 1, the upper electrode comprising:
- a first upper electrode material formed on the substrate; and
- a second upper electrode material formed on the first upper electrode material,
- wherein portions of the second upper electrode material corresponding to the R, G, B organic thin film layers each have a different thickness.
5. The organic light emitting device of claim 4, wherein the first upper electrode material is comprised of at least one or more materials selected from LiF and Mg:Ag, and the second upper electrode material is comprised of at least one or more materials selected from IZO and ITO.
6. The organic light emitting device of claim 4, wherein the second upper electrode material has a thickness of approximately 800 Å to approximately 2400 Å.
7. The organic light emitting device of claim 6, wherein the second upper electrode material has a thickness of approximately 800 Å to approximately 1600 Å to obtain a high luminous efficiency.
8. The organic light emitting device of claim 6, wherein the second upper electrode material has a thickness of approximately 800 Å to approximately 2400 Å to obtain a high color purity.
9. The organic light emitting device of claim 4, wherein the portion of the second upper electrode material, corresponding to the R organic thin film layer, has a thickness of any one thickness in the range of approximately 1200 Å to approximately 2400 Å.
10. The organic light emitting device of claim 4, wherein the portion of the second upper electrode material, corresponding to the G organic thin film layer, has a thickness of approximately 800 Å.
11. The organic light emitting device of claim 4, wherein the portion of the second upper electrode material, corresponding to the B organic thin film layer, has a thickness of approximately 1600 Å.
12. The organic light emitting device of claim 1, wherein the upper electrode comprises:
- a first upper electrode material formed on the substrate; and
- a second upper electrode material formed on the first upper electrode material, the second upper electrode material having portions of different thicknesses which correspond to the R, G, B organic thin film layers,
- wherein the second upper electrode material includes:
- first layers for R, G, B unit pixels, the first layers independently formed in different thicknesses on respective portions of the first upper electrode material that correspond to the R, G, B organic thin film layers; and
- a second layer formed in a uniform thickness on the first layers and the first upper electrode material.
13. The organic light emitting device of claim 12, wherein the first upper electrode material is comprised of at least one or more materials selected from LiF and Mg:Ag, and the first and second layers of the second upper electrode material are each comprised of at least one or more materials selected from IZO and ITO.
14. The organic light emitting device of claim 12, wherein the sum of the thickness of any one of the first layers and the thickness of the second layer of the second upper electrode material is approximately 800 Å to 2400 Å.
15. The organic light emitting device of claim 1, wherein the upper electrode comprises:
- a first upper electrode material formed on the substrate; and
- a second upper electrode material formed on the first upper electrode material, the second upper electrode material having portions of different thicknesses which correspond to the R, G, B organic thin film layers,
- wherein the second upper electrode material includes:
- a first layer formed on the first upper electrode material in a uniform thickness; and
- second layers for the R, G, B unit pixels, each of the second layers independently formed in a different thickness on respective portions of the first layer that correspond to the R, G, B organic thin film layers.
16. The organic light emitting device of claim 15, wherein the first upper electrode material is comprised of at least one or more materials selected from LiF and Mg:Ag, and the first and second layers of the second upper electrode material are each comprised of at least one or more materials selected from IZO and ITO.
17. The organic light emitting device of claim 15, wherein the sum of the thickness of the first layer and the thickness of any one of the second layers of the second upper electrode material is approximately 800 Å to 2400 Å.
18. The organic light emitting device of claim 1, wherein an emitting light is emitted in direction of the upper electrode.
19. A method of forming an organic light emitting device having R, G, B unit pixels, in which the R, G, B unit pixels comprise R, G, B lower electrodes formed on a substrate, R, G, B organic thin film layers each formed on the R, G, B

lower electrodes, and an upper electrode formed over the substrate, the method comprising the steps of:

forming the upper electrode, the upper electrode being formed by:

forming a first upper electrode material on the substrate; and

forming a second upper electrode material on the first upper electrode material, the second upper electrode material having portions, each portion having a different thickness that corresponds to one of the R, G, B unit pixels.

wherein forming the second upper electrode material includes:

forming on portions of the first upper electrode material that corresponds to the R, G, B organic thin film layers, one or more first layers, each of the first layers having a different thickness that corresponds to one of the R, G, B unit pixels, respectively; and

forming a second layer in a uniform thickness on the first layer and the first upper electrode material.

20. The method of claim 19, wherein the first layers for the R, G, and B unit pixels of the second upper electrode material are deposited using a fine metal mask so that each of the R, G, and B unit pixels has the different thickness.

21. The method of claim 19, wherein the first layers for the R, G, and B unit pixels of the second upper electrode material are patterned by three-time repetition of a photolithography so that each of the R, G, and B unit pixels has the different thickness.

22. The method of claim 19, wherein the first layers for the R, G, and B unit pixels of the second upper electrode material are patterned by a single photolithography process using a halftone mask so that each of the R, G, and B unit pixels has the different thickness.

23. The method of claim 19, wherein an emitting light is emitted in direction of the upper electrode.

24. A method of forming an organic light emitting device with R, G, B unit pixels, in which the R, G, B unit pixels comprise R, G, B lower electrodes formed on a substrate, R, G, B organic thin film layers each formed in the R, G, B

lower electrodes, and an upper electrode formed over the substrate, the method comprising the steps of:

forming the upper electrode, the upper electrode being formed by:

forming a first upper electrode material on the substrate; and

forming a second upper electrode material on the first upper electrode material, the second upper electrode material having portions, each portion having a different thickness that corresponds to one of the R, G, B unit pixels. R, G, B

wherein forming the second upper electrode material includes:

forming in a uniform thickness on the first upper electrode material a first layer; and

forming second layers for the R, G, B unit pixels on portions of the first layer that correspond to the R, G, B organic thin film layers, one or more second layers, so that each of the R, G, and B unit pixels has the different thickness.

25. The method of claim 24, wherein the second layers for the R, G, and B unit pixels of the second upper electrode material are deposited using a fine metal mask so that each of the R, G, and B unit pixels has the same thickness.

26. The method of claim 24, wherein the second layers for the R, G, and B unit pixels of the second upper electrode material are patterned by three-time repetition of a photolithography process so that each of the R, G, and B unit pixels has the different thickness.

27. The method of claim 24, wherein the second layers for the R, G, and B unit pixels of the second upper electrode material are patterned by a single photolithography process using a halftone mask so that each of the R, G, and B unit pixels has the different thickness.

28. The organic light emitting device of claim 24, wherein an emitting light is emitted in direction of the upper electrode

* * * * *

专利名称(译)	高效率的平板显示器及其制造方法		
公开(公告)号	US20050017630A1	公开(公告)日	2005-01-27
申请号	US10/896011	申请日	2004-07-22
[标]申请(专利权)人(译)	RYU SEOUNG YOON 宋承宪YONG		
申请(专利权)人(译)	RYU SEOUNG-YOON 宋承宪勇		
当前申请(专利权)人(译)	三星DISPLAY CO. , LTD.		
[标]发明人	RYU SEOUNG YOON SONG SEUNG YONG		
发明人	RYU, SEOUNG-YOON SONG, SEUNG-YONG		
IPC分类号	H05B33/26 H01L27/32 H01L51/52 H05B33/00 H05B33/10 H05B33/12 H05B33/22		
CPC分类号	H01L27/3211 H01L51/5221 H01L51/5203		
优先权	1020030051811 2003-07-26 KR		
其他公开文献	US7816857		
外部链接	Espacenet USPTO		

摘要(译)

公开了一种有机发光器件。在一个实施方案中，有机发光器件包括形成在基板上的红色(R)，绿色(G)和蓝色(B)下电极。R，G，B有机薄膜层分别形成在R，G，B下电极上。另外，在衬底上形成上单层或多层电极。对应于R，G，B有机薄膜层的上电极的部分分别形成成为具有不同的厚度。还公开了使用精细金属掩模，半色调掩模以及单个和多个光刻工艺形成上电极的各种方法。

